

High Quality German Guitar Parts



ABM



Series 2500
Guide





ABM

Series 2500

Guide

Introduction

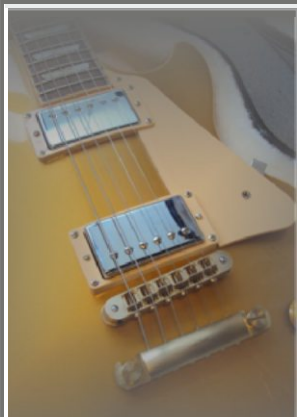

Thank you for your interest in the Bridge Series 2500!

This manual makes it easy to select the suitable model for your guitar up to a custom made version.

You will also find a great variety of bolts & adapters to solve individual mounting topics.

Visit the FAQ-Section for assistance & learn more about the difference that makes ABM-Bridges incomparable.

If you have further question do not hesitate to contact us.

Yours faithfully

The entire ABM-Team

Table of Contents



Page 2	<i>ABM 2500-RE (ABR1-Type)</i>
Page 3	<i>ABM 2500 (ABR1 on Nashville Posts)</i>
Page 4	<i>ABM 2504 (Nashville)</i>
Page 5	<i>ABM 2506 (Asian Big Stud, M8)</i>
Page 6	<i>ABM 2500-X (Custom)</i>
Page 7	<i>ABM 3020 / 3020a (Stoptail)</i>
Page 8	<i>Accessories (Studs & Adapters)</i>
Page 9	<i>Accessories (Saddles)</i>
Page 10	<i>FAQ - String Saddle Notches</i>
Page 10	<i>FAQ - String Saddle Replacement</i>
Page 11	<i>FAQ - Notching String Saddles</i>
Page 12	<i>FAQ - Radius, Purchasing Spareparts</i>
Page 13	<i>INSIDE ABM - From a „Block“ to a Bridge</i>
Page 14	<i>INSIDE ABM - Secrets of Tone</i>



Classic T.O.M-Bridge

ABM

2500-RE In memory of ABR-1

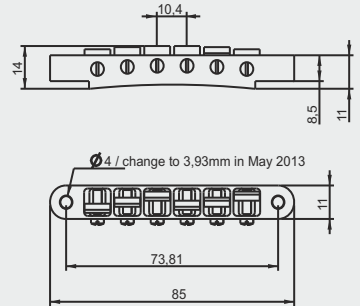

ABM2500-RE

Type: Compatible to „LP-Customs, Reissues & Vintage Guitars“ that are using ABR-1 Bridge Dimensions. Please check your guitar first! 12" radius

String-Spacing: 10,4mm / 52mm, fine adjustment possible (saddles are not pre-notched!)

Stud-Spacing: 73,66 to 73,81mm for 3,5 - 3,9mm threaded Rods

Studs: **May 2013:** #6-32 UNC Threaded Bolts with a length of 30mm and Brass Wheels
Untill then the bridge comes with M4/30mm Steel Studs & Wheels M4*

Finishes: Nickel, Chrome, 24K-Gold, Black Chrome, Aged Nickel, Aged Gold

Versions: **2500-RE:** Bell Brass Body, Bell Brass Saddles

NEW

2500a-RE: Aluminum Body, Bell Brass Saddles (available in Summer of 2013)

2500s-RE: Carbon Steel Body, Bell Brass Saddles (available in Summer of 2013)

Packing Unit: Bridge, pair of bolts & wheels, free accessory-pack, protector box

Accessories: **2500Saddles:** Set of 3 Saddles, Screws and Circlips for 2500/2500-RE, for a complete saddle exchange please obtain two sets!

NEW

2500Saddles PN: Pre-Notched, Set of 3 Saddles, screws and circlips for 2500/2500-RE, for a complete saddle exchange please obtain two sets!

2544 Threaded Bolt & Wheel, Pair M4x30mm Steel Bolts and Bell Brass Wheels (included in delivery of 2500-RE)

2548-RE ABR to M8 Adapter, long, Pair, 3,6mm to M8

* We will attach the original sized bolts and wheels starting in May 2013. In the meantime please use the original bolts and wheels of your guitar.



2500

Slender ABR for Nashville

ABM

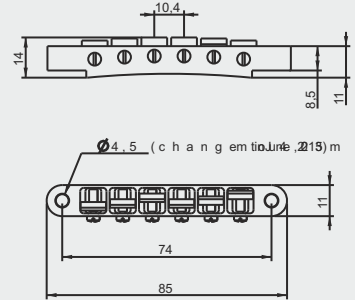

ABM2500

Type: Compatible to most LP-Standard, Studio and Nashville-Type Guitars. Please check your guitar first and note, that the ABR design offers less intonation range than the wider Nashville type #2504 (next page)!

String-Spacing: 10,4mm / 52mm, 12" radius

Stud-Spacing: 74mm

Studs: 4mm bolt to M5 thread, M5 bushing (12mm heel & 7,1mm dia.). #2545

Finishes: Nickel, Chrome, 24K-Gold, Black Chrome, Aged Nickel, Aged Gold

Versions: 2500: Bell Brass Body, Bell Brass Saddles

NEW

2500a: Aluminum Body, Bell Brass Saddles (available in 2013)

2500s: Carbon Steel Body, Bell Brass Saddles (available in 2013)

Packing Unit: Bridge, Pair of studs & bushings, free accessory-pack, protector box

Accessories: **2500Saddles** (Set of 3 Saddles, Screws and Circlips for 2500/2500-RE, for a complete saddle exchange please obtain two sets!)

NEW

2500Saddles PN (Pre-Notched), Set of 3 Saddles, screws and circlips for 2500/2500-RE, for a complete saddle exchange please obtain two sets!

2545 Stud & Wheel, Pair (scope of delivery)

2548 Adapter 4mm to M8, short (25mm), Pair, 3,6mm to M8

2548-L Adapter 4mm to M8, long (34mm), Pair, 3,6mm to M8



2504

The Contemporary Classic

ABM

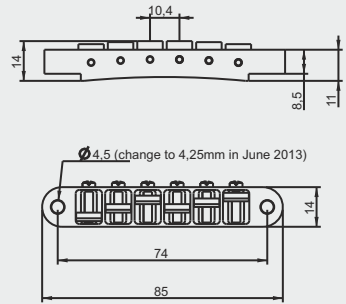
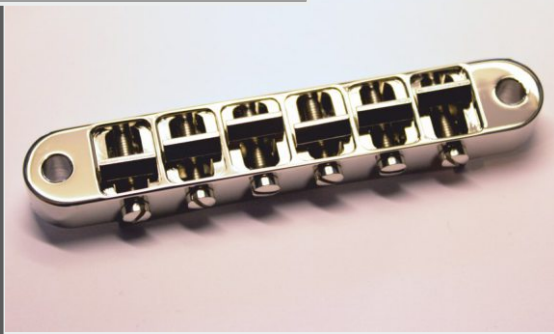

ABM2504

Type: *Compatible to most LP-Standard, LP-Studio and Nashville-Type Guitars. Please check your guitar first!*

String-Spacing: *10,4mm / 52mm, 12" radius*

Stud-Spacing: *74mm*

Studs: *4mm bolt to M5 thread, M5 bushing (12mm heel & 7,1mm dia.) , #2545*

Finishes: *Nickel, Chrome, 24K-Gold, Black Chrome, Aged Nickel, Aged Gold*

Versions: *2504: Bell Brass Body, Bell Brass Saddles*

NEW

2504a: Aluminum Body, Bell Brass Saddles (available in 2013)

2504s: Carbon Steel Body, Bell Brass Saddles (available in 2013)

Packing Unit: *Bridge, Pair of studs & bushings, free accessory-pack, protector box*

Accessories: *2504Saddles: Set of 3 Saddles, Screws and Circlips for 2504/2506, for a complete saddle exchange please obtain two sets!*

NEW

2504Saddles PN: Pre-Notched, Set of 3 Saddles, Screws and Circlips for 2500/2500-RE, for a complete saddle exchange please obtain two sets!

2545 Stud & Wheel, Pair (scope of delivery)

2548 Adapter 4mm to M8, short (25mm), Pair, 3,6mm to M8

2548-L Adapter 4mm to M8, long (34mm), Pair, 3,6mm to M8

2506

M8 „Big Foot“ Nashville

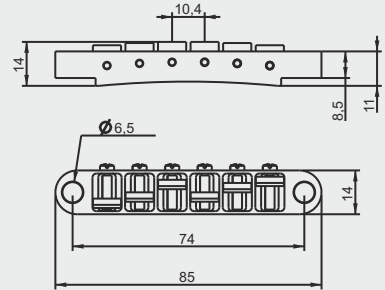

ABM2506

Type: Compatible to many Asian-Style LP-Guitars which bridges are mounted on M8 threaded bolts. Please check your guitar first! You may have to use longer Studs (2568-L), if your guitar has got a strong neck angle.

String-Spacing: 10,4mm / 52mm, 12" radius

Stud-Spacing: 82mm (up to 82,50mm)

Studs: M6mm bolt to M8 thread, (25mm long*) M8 bushing (diameter: 15mm heel & 11,28mm bushing) * A longer stud/bushing is available (34mm long) as accessory item #2568-L for guitars with an extended height adjustment.

Finishes: Nickel, Chrome, 24K-Gold, Black Chrome, Aged Nickel, Aged Gold

Versions: **2504:** Bell Brass Body, Bell Brass Saddles

NEW

2506a: Aluminum Body, Bell Brass Saddles (available in 2013)

2506s: Carbon Steel Body, Bell Brass Saddles (available in 2013)

Packing Unit: Bridge, Pair of studs & bushings (25mm) , free accessory-pack, protector box

Accessories: **2504Saddles** (Set of 3 Saddles, Screws and Circlips for 2504/2506, for a complete saddle exchange please obtain two sets!)

NEW

2504Saddles PN (Pre-Notched, Set of 3 Saddles, Screws and Circlips for 2500/2500-RE, for a complete saddle exchange please obtain two sets!

2568 Stud & Wheel, Pair (scope of delivery)

2568 Adapter 4mm to M8, short (25mm), Pair, 3,6mm to M8

2568-L Adapter 4mm to M8, long (34mm), Pair, 3,6mm to M8

2500-X

Your personalized T.O.M.

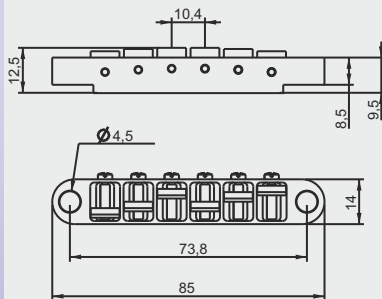

ABM2500X (for example!)

Type:

A lot of guitars are made without keeping industrial standards. Often stud spacing or stud type of a bridge vary. So we decided to offer the „ABM 2500-X“ bridge that is made specially for your needs!

Based upon the outline dimensions of ABM 2500-RE, 2500, 2504, 2506 you can change the following bridge-parameters:

1. Bridge Bolt-Hole: Diameter and Stud Spacing/Position!
2. Bridge-Height: A minimizing of 1,5mm is possible!
3. Free Choice of: Stud/Bushing Method - Accessories (e.g.: ABR-1 for M8 Studs...)
4. String-Saddles: Please choose between Plain or Pre-Notched Saddles!
5. Finishes: Nickel, Chrome, 24K-Gold, Black Chrome, Aged Nickel, Aged Gold!

Versions:

2500x: Bell Brass Body, Bell Brass Saddles

NEW

2500xa: Aluminum Body, Bell Brass Saddles (available in 2013)

2500xa: Carbon Steel Body, Bell Brass Saddles (available in 2013)

Pricing:

Between 198€ and 249€* (depending on your wishes/plating)
We can even build a Stop-Tailpiece with your dimensions, if possible (*Net-Retail-Price). **Lead Time:** 8 to 12 weeks.

Contact Person:

Custom made 2500X Series are directly available at ABM.
Please feel free to ask for your specific offer.

Prices vs. Result:

Our Custom Service is outstanding worldwide. This bargain is exceptional in comparison to the invest of a new guitar. Each instrument can profit from a personalized ABM Bridge that was made upon your wishes!



Stop-Tailpiece

3020/3020a

An elegant jewel

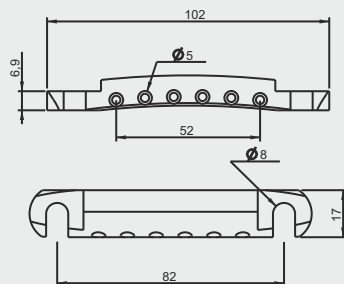

ABM 3020/3020a

Type: Classic Stop-Tailpiece, compatible to all LP-Style Guitars who provide a Stud Spacing of 82mm to 82,5mm and have got build in 5/16" bolt bushings. For guitars with M8 bolts we provide ABM 30208 Studs.

String-Spacing: 10,4mm / 52mm, 12" radius

Stud-Spacing: 82mm (up to 82,5mm possible)

Studs: Bolts with a 5/16" thread, (13mm Head with 7,2mm Bridge- Aperture, overall length of 36mm, Bushing: 11,28x25mm with 5/16" inside thread. For guitars with M8 bolts we provide the ABM 30208 Studs as accessory!

Finishes: Nickel, Chrome, 24K-Gold, Black Chrome, Aged Nickel, Aged Gold

Versions: **3020:** Milled Bell Brass Body, Bell Brass Studs
3020a: Milled Aluminum Body, Bell Brass Studs

NEW

3020s: Milled Carbon Steel , Bell Brass Studs (available in Spring 2013)

Packing Unit: Bridge, Pair of 5/16" Studs & Bushings, free Accessory-Pack, Protector Box

Accessories: **302516** Studs/Bushings 5/16" , Set of 2 Pairs
30208 Studs/Bushings M8, Set of 2 Pairs

Series 2500

Bolts & Adapters

All following parts are available in these finishes: Nickel (n), Chrome (c), Gold (g) Chrome (b), Aged Nickel (n-aged) & Aged 24K-Gold (g-aged)

2544 Threaded Bolt & Wheel, Pair (Content of 2500-RE)

M4x30mm Steel Bolt and Bell Brass Wheel 16x2mm* (#6-32 UNC will come in May 2013)



*We will change the technical data in May 2013 to the original #6-32 UNC threaded bolts & brass wheels. Some LP-models use smaller imperial studs with a diameter of 3,35mm or less. We can support these models with a custom made bridge that will fit your small studs.

2545 Nashville Stud & Bushing, Pair (Content of 2504/2500)

4mm Head to M5 - Bolt with 25mm length and Bushing 10x7mm incl. 1,5x 12mm heel



2548 - Nashville 4mm Stud to M8, Pair (For 2504/2500 on M8 bolts)

4mm Head to M8, 25mm length over all (to adapt a 2504 to a M8 bushing)



2548-L - Nashville Stud to M8, long, Pair (to adapt a 2504 to a M8 bushing)

4mm Head to M8, 34mm length over all, made for guitars with a higher bridge position.



2548-RE - ABR to M8 adapter, long, Pair

3,75mm to M8 for using a classic 2500-RE on „M8 Big Studs“, 34mm length over all



2568 - Asian Big Head to M8 Studs, Pair (content of 2506)

6mm to M8, Stud length over all 25mm with Bushing



2568-L - Asian Big Head to 8 Studs, Pair

6mm to M8, Stud length over all 34mm for guitars with higher bridge position.



302516 - Tailpiece-Stud/Bushing Set, (5/16") Pair

Bolt-Head 13mm with Bridge Aperture of 7mm, length 36mm, Bushing: 11.28x25mm

30208 - Tailpiece-Stud/Bushing Set, (M8) Pair

Bolt-Head 13mm with Bridge Aperture of 7mm, length 36mm, Bushing: 11.28x25mm



Series 2500

Saddles & Parts

2500Saddles

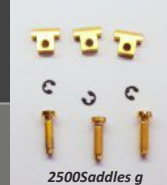
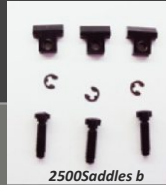

Set of 3 saddles, 3 screws and 3 circlips for 2500/2500-RE
for a complete bridge please obtain two sets! Also available as „n-aged“ and „g aged“

2504Saddles

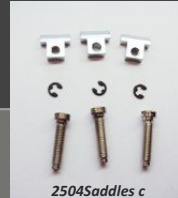

Set of 3 saddles, 3 screws & 3 circlips for 2504/2506
for a complete bridge please obtain two sets! Also available as „n-aged“ and „g aged“

2500Saddles PN (Pre-Notched)

Set of 3 saddles, 3 screws & 3 circlips for 2504/2506-RE
for a complete bridge please obtain two sets! Available as n, g, b, c, „n-aged“ and „g aged“



2504Saddles PN (Pre-Notched)

Set of 3 saddles, 3 screws & 3 circlips for 2504/2506
for a complete bridge please obtain two sets! Available as n, g, b, c, „n-aged“ and „g aged“



Series 2500
FREQUENTLY ASKED QUESTIONS
1.) Why do we not pre-notch string saddles of ABM 2500 Bridges?

All involved parts must alligned for a straight string course in a row! Like nut-notches, fretboard & pickup pole-pieces up to the guitar bridge saddle-notches. But this demand is not often given by factory presets. Every guitarist plays his own style (string bending-range e.g.) with his own choice of strings gauge. The neck radius may vary from the avarage 12".

So you need to have the chance to arrange your personal notch setting in depth and position! Here are 3 ways of finishing notches:

- A. Making them by yourself (A presentation for handymen is given on the next page).
- B. An experienced guitar-technician could do the job for you!
(In case you are insecure about the procedure and the purchase of the needed tools).
- C. You can obtain pre-notched saddles and finish them by yourself.
(When your guitar provides best requirements with middle positioned notches).

2.) Replacing the string saddles

Tools: Slotted screwdriver (S = 1,0mm), a piece of rubber hose (makes the work safe & easy, with a 4,5mm bore diameter) and fine long-nose-pliers.

Tip: Our 2500 bridge does not have an overall spring for fixing the saddles as it makes noise. We use very thin Circlips. If you want to replace a saddle or change its direction **use new Circlips always!** Otherwise they may break and the bridge function is defective! (ABM sparepart-sets are named on page 10).

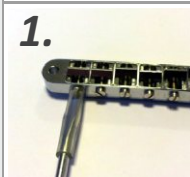

Tip: Fitting a rubber sleeve above the screwdrivers knife will help you to hold the screw head properly (a wellmeant hint from our assembly department :-).

1.

Action 1. Please untighten the intonation screw. When it becomes harder to turn (the circlip will hold the screw) please go on further very slowly and carefully. A good method to free the circlip from the screw's heel is to alternate forward and backward screwing in very small steps. After the circlip is gone, change the direction or replace the saddle. 2. Tigthen them again by zooming in the saddle insert with leaving enough space for inserting the new Circlip to the screws heel.

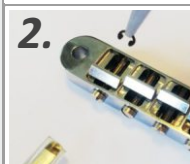
2.

If you feel insecure about the string saddles replacment procedure please contact a specialist to do it! We assume no liability! Please take care about your health.

3.) Notching the string saddles.



A round „U-Groove“ may be the best notch-type, but you need several files following the exact string gauges. Buzzing noise may occur when a string does not complete the notch („Sitar-Effect“). Notches wear out and the problem will occur some day in either case. We prefer „V-Cut“-Notches with their long lasting fit and best tone transmission too.

Which Tools do you need? A steel saw blade (0,2 to 0,3mm), a fine triangular-file and a keen marker from a hardware store for some bucks. A towel prevents your guitar from scratches.



If you feel insecure about string saddle replacement please contact a specialist to do the job for you! Please take care about your health. We assume no liability!

General hints / Preparation:

- A. Do not cut notches parallel to the saddle surface. Choose an angle of 30° down to the tailpiece to reach a dedicated string rest at the front edge of the saddle. Keep care that you do not hurt the bridge side wall of the bridge. **File the cut with very short strokes!**
- B. Please assign the string course to the string saddle theoretical. A T.O.M-Bridge is mounted tilted for a proper intonation normally. So the notch has to be set sloped as the bridge is out of square from string course. The String spacing or radius may differ from the average (10,4mm, 12"), so check the best position first before starting the filing procedure.

Procedure:

1. Spread the strings to the wanted spacing (nut-notch, pickup pole-pieces and the perfect saddle notch position in a row). Leave enough space for both exterior strings to the fretboard sides. Mark both outlines of the string to the saddle top by a pen. Then release and pull the string aside and wrap it into a towel to prevent the guitar from scratches.
2. Mark off the guide-notch in the middle of the assigned position with the sawblade softly (remember 30° or more degrees downwards). It should be just a slight slot for leading the file in step 3 properly!
3. Cut the final notch with a triangular file (again 30°). Please consider the string gauges as base for the notch width & depth: A „V-Cut“ should be sized with one third up to half of the string diameter, but not more at the support point of the string.

As no one is born as a master you will find a reserve saddle-set in the original package of your ABM Bridge or take a look to the spare parts page. You can even purchase pre-cut saddles.

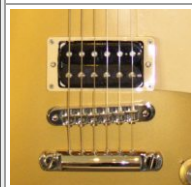
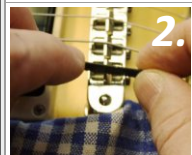
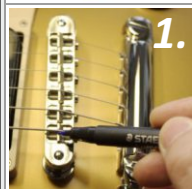

4.) Different Fretboard radii possible? Yes!

The 2500 series guitar bridge is staggered for a 12" fretboard radius & 52mm spacing. This is the physical theory.

The practise shows that the best radius setting on a bridge depends on several other parameters of your guitar like the neck trussrod adjustment, string spacing, bridge and pickup position and string gauges!

Compatibility for 9,45" or a compound radius (e.g. 12" to 16"): We deliver our bridges without notches, so you can modify the saddle notch depth by yourself with special tools to reach the wanted radius easily. You may ask a guitar technician or luthier to make this job.

5.) Does an ABM 2500 Bridge provides more intonation range?



Yes, in comparison to the actual original ABR-1 and Nashville Bridge.
(dimensions vary because of the imprecision of die-cast bridges, even at 3rd-party products).

ABR-1, **3,7mm** (+ 3mm, if the saddles is turned) = max. 6,7mm
ABM2500/2500-RE, **4,6mm** (+ 3mm, dito) = max. **7,6mm**

Nashville, **6,7mm** (+ 2,5mm, if the saddles is turned) = max. 9,2mm
ABM2504/2506, **7,5mm** (+ 3mm, dito) = max. **10,5mm**

6.) How to purchase spareparts?

ABM 2500 Spareparts (page 9) are available at your local music store. You can also purchase them directly at ABM for retail prices.

7.) Warranty

We issue a producer warranty of **3 years** from the date of purchase for function and plating*. Please note that we cannot exchange an used bridge, but we will grant for the rectification of a defect that is caused by ABM from the date of purchase by exchanging the faulty parts.

„Aged“ Bridges: These parts are not covered by the warranty for the finish, as the aging-process destroys the plating and the parts are vulnerable for further environmental influences.

*We suspend warranty claims caused by extreme acidic human sweat or mechanical abraision.

1.) From a block to the bridge...

Based upon Ted Mc Carty's genius idea of the ABR1 Bridge and the later invented Nashville model, we learned a lot about the Tuneomatic Design while developing Series 2500.

The final result of our development work is a groundbreaking guitar-bridge that brings your guitar to a new quality of sound. **But how?**

The main duty of a guitar bridge is to transmit the guitar players message to the guitar body best.



All ABM bridges are milled from one block of high compressed metal with a complex CNC-technology and craftsmanship.

Each ABM bridge offers the same high quality in production precision and material selection!

We do not produce low-budget die-cast products. The Die-Cast process is very simple but causes an instable material with many inclusions such as air-bubbles and other impurities. Like a hidden worm in an apple!

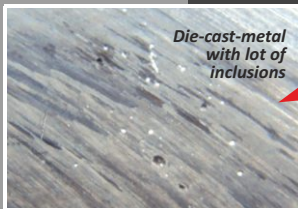

Die-cast-metal with lot of inclusions

Do you have ever seen this fact under the shiny chrome? We do not think so. So we cutted a pair of tailpieces for you to clarify the facts.

Experienced specialists can tell you a thing or two about „dead strings“ and the reason why... An air-bubble under your string saddles could decrease the tone transfer and sustain badly!

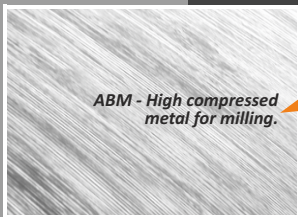

ABM - High compressed metal for milling.

Base for ABM milling-work is drawn metal with a much better homogenous and high density.

This secret is one of the most important parameter for a well sound transmission and a proper bridge function.

Series 2500
Secrets from Research & Development...
2.) Technical Aspects of our T.O.M

Our milled string-saddle has got precise defined edges and flanks. The saddle-shoulder presents full contact to the bridge. No rattle of the spring occurs due the intonation-screw is anchored by a circlip! An ABM T.O.M-Bridge offers 0,8 to 1,3mm more intonation-range than the actual original ABR-1 and Nashville bridge features.

We offer cilindric bores for full bolt to bridge contact! So we reach best sound transfer. Most competitors provide conical holes as result of the casting process. There is just a small contact given between bridge and top end of the stud. The mid & lower end of the stud have got no contact to the bridge at all!

Beside all precison we recognized that the bridge body must have a little play between bridge and posts to evolve rich harmonics and sustain. It seems, that the bridge must „swing“ on ist bolts.

3.) Locking vs.Non-Locking

*The Locking function is practically for a safe string replacement or for tremolo setups. **But Locking affects the tonal character totally!***

The sound loses its natural dynamic, harmonic structure and sustain.

It seems that the locking function works as damper for our milled bridge body and disturbs its oscillating. We had to learn that sometimes it is better to follow the tone instead the function!

Each ABM product provides a „special gift“.

It is up to you to explore your tonal experience with precise ABM bridges made of solid Brass, Carbon Steel and Aluminum. We are curious about your opinion!

Within the year 2013 we will confirm our technology advantage with scientific proven test series to make your final choice much easier.

4.) Environmental basics in building an ABM bridge



Many asian concerns produce „premium“ guitar parts based upon a weekly working time of 60 hours and wages about ten Dollars each day..

Together with intense pollution of waters and the whole environment due liquid waste of the plating process you see a real toxic combination of exploitation of nature and human being.

Sometimes we all forget how our „cheap jacks“ are made.

In contrast **ABM is keeping the fair trade concept responsible** while holding dignified conditions of work , human rights and the high Environmental Guidelines of the European Union.

All of our parts are designed and produced in Berlin, Germany exclusively.

Our waste is nearly zero as we recycle all needless metal parts and wrapping to 100%. The plating shop is ISO 9001 certified and cleans its effluents very efficient without any environment pollution.

Traditional craftsmanship within a team of specialists and „state-of-the-art“ CNC-manufacturing guarantee you a high-end and skillful designed guitar product that you could join with a good conscience too.

You have the decision on your hands which parts your guitar should wear.

5.) Basic Information

ABM High Quality German Guitar Parts - GmbH
Wolfener-Str.36
12681 Berlin - Germany



Hotline: +49 (0) 30 - 930 211 22*

Fax: +49 (0) 30 - 930 99 48

Email: info@abm-guitarparts.de

Web: www.abm-guitarparts.com

Guitar Parts for You!

Since 64 Years

* Monday to Thursday - 7 AM to 5 PM CET, Friday - 7 AM to 1 PM CET